

VT VALVE

MAX & SB SERIES



HIGH PERFORMANCE BUTTERFLY VALVE



HIGH PERFORMANCE SEGMENT VALVE & CONTROL VALVE

SIZE RANGE

2" thru 48" (20A ~ 1200A), Optional thru 120"
ANSI Class 150/300, JIS10K / 20K

SERVICE

Segment ball is quarter turn control valve mainly recommended for throttle service, but it is also applicable for shut off service. Segment ball is in V-notch design with strong cutting force and self-cleanness, especially suitable for control of medium containing fibre and tiny solids. Therefore, it is widely used in the control systems in industries such as pulp and paper, petrochemistry, petroleum, chemical fibre, power, metallurgy, pharmacy, environmental protection etc.

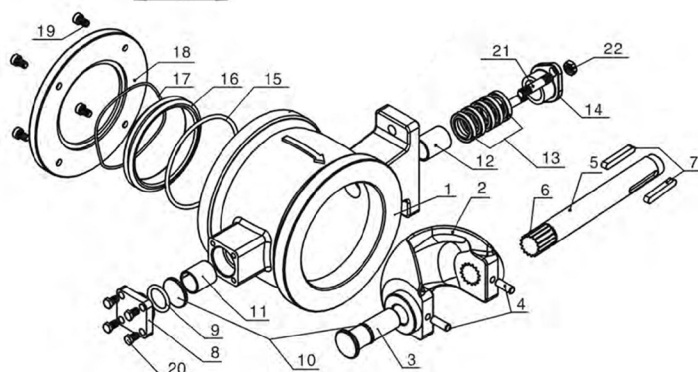
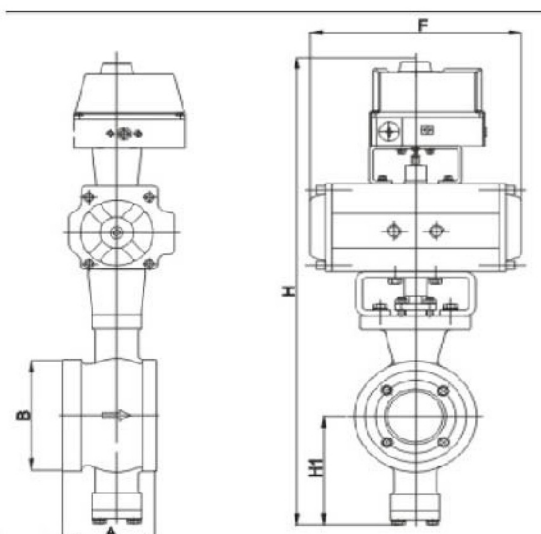

Code	A	B	F	H1	H
25	62	68	178	87	515
32	62	78	178	87	515
40	62	85	178	87	525
50	75	100	214	97	550
65	90	120	246	112	585
80	100	130	246	112	600
100	115	158	295	122	625
125	129	180	340	142	650
150	160	216	398	165	750
200	200	268	478	195	850
250	240	325	562	237	970

PARTS LIST

No.	Name	Material
1	Body	CF8 CF8M
2	Ball	CF8 CF8M with Hard Chromium
3	Lower Shaft	17-4PH
4	Cylindrical Pin	17-4PH
5	Upper Shaft	17-4PH
6	Spline	17-4PH
7	Flat Key	17-4PH
8	Cover plate	CF8 CF8M
9	O-ring	Viton
10	Gasket	PTFE
11	Self-Lubrating Bearing	Composite Material
12	Self-Lubrating Bearing	Composite Material
13	Packing	PTFE
14	Gland	CF8
15	O-ring	Viton
16	Seat	SS316L
17	Wavy Spring	SS316
18	Retainer	SS304 SS316
19	Socket Head Screw	SS304 SS316
20	Hexagon Screw	SS304 SS316
21	Stud	SS304 SS316
22	Hexagon Nut	SS304 SS316

Maximum Allowable Differential Pressure & Rated CV

DN	Wafer connection		Wafer connection		Rated Cv
	Max.shut off dp. (bar)	Max.control dp. (bar)	Max.shut off dp. (bar)	Max.control dp. (bar)	
25	50	35	40	35	27
32	50	35	40	35	47
40	50	35	40	35	70
50	50	35	40	35	110
65	50	35	40	35	170
80	50	35	40	35	280
100	40	25	40	25	410
125	40	25	40	25	750
150	40	25	40	25	980
200	35	25	35	25	1720
250	35	20	35	20	2900
300			30	10	3800
350			30	10	7000
400			30	10	9800
450			30	10	12000
500			30	10	23000

HOW TO ORDER

SB	080	F1	16	C	C	1	V
1	2	3	4	5	6	7	8

1 VALVE TYPE

SB | Segment Ball Valve

2 VALVE SIZE

80 | DN 80 / 3"
 100 | DN 100 / 4"
 150 | DN 150 / 6"
 200 | DN 200 / 8"
 250 | DN 250 / 10"
 XXX | DN XXX

3 CONNECTION TYPE

F1 | FLANGELESS / WAFER

4 PRESSURE RATING

10 | JIS 10K
 16 | PN 16
 150 | ANSI 150

5 BODY MATERIAL

C | CFB + STELLITE
 F | CF8M + STELLITE

6 BALL MATERIAL

C | CFB
 F | CF8M

7 SEAT

1 | METAL - SS316L
 2 | RTFE

8 O RING

V | VITON

METAL - SEATED

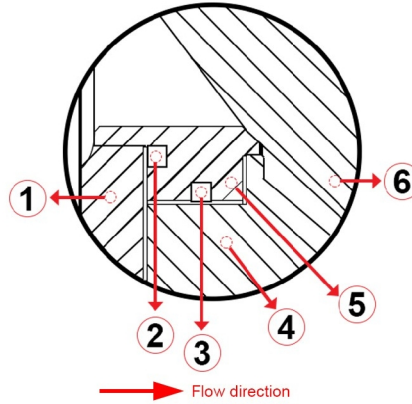

METAL SEATED

No.	Name	Temp. Range
1	Retainer	-20~160 -20~230
2	Spring	
3	O - Ring	
4	Valve Body	
5	Metal Seat	
6	Ball	

PTFE - SEATED

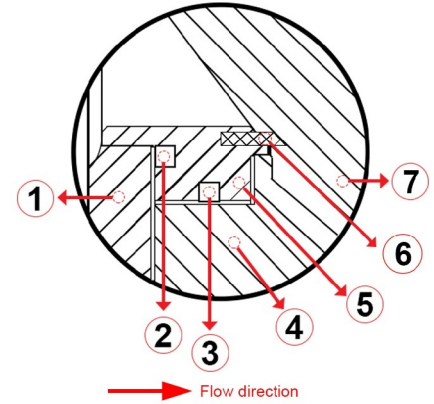

PTFE - SEATED

No.	Name	Temp. Range
1	Retainer	-20~160
2	Spring	
3	O - Ring	
4	Valve Body	
5	Seat Ring	
6	PTFE	
7	BALL	

VTV MAX AT VERTICAL STERILIZER SYSTEM

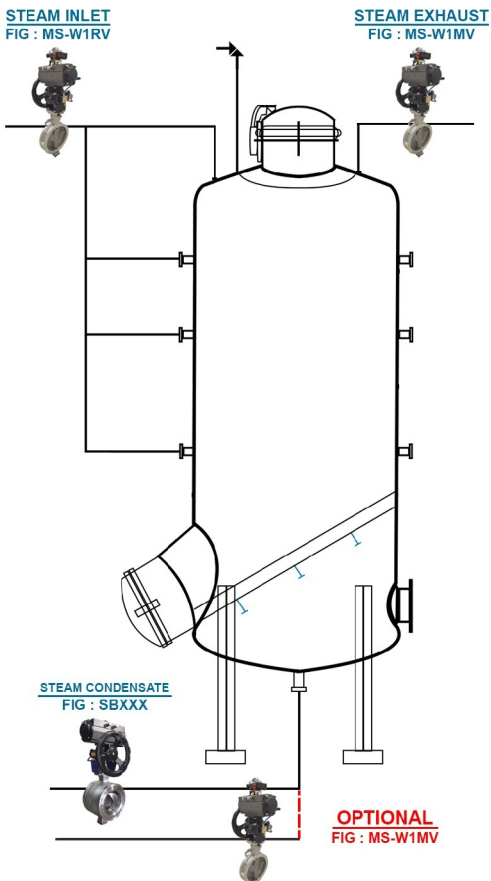

VTV MAX & ADCA CONTROL VALVE BPR SYSTEM

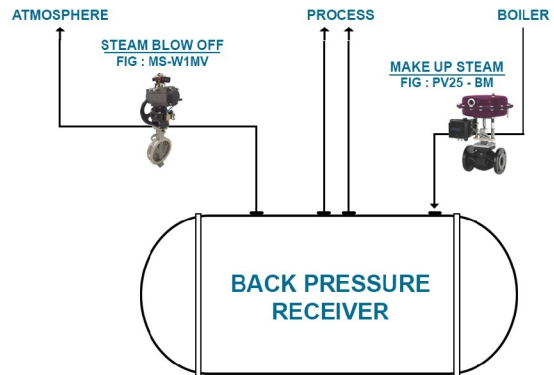

VTV MAX AT HORIZONTAL STERILIZER SYSTEM

